



TAI-SAW TECHNOLOGY CO., LTD.

No. 3, Industrial 2nd Rd., Ping-Chen Industrial District,
Taoyuan, 324, Taiwan, R.O.C.

TEL: 886-3-4690038 FAX: 886-3-4697532

E-mail: tstsales@mail.taisaw.com Web: www.taisaw.com

Product Specifications Approval Sheet

Product Description: 850 MHz SMD 3.0X3.0 mm SAW Resonator

TST Part No.: TC0634A

Customer Part No.: _____

Customer signature required
Company: _____
Division: _____
Approved by : _____
Date: _____

Checked by: _____ Kazuma Lee *Kazuma Lee*

Approved by: _____ Andy Yu *Andy Yu*

Date: _____ 2019/4/25

1. Customer signed back is required before TST can proceed with sample build and receive orders.
2. Orders received without customer signed back will be regarded as agreement on the specifications.
3. Any specifications changes must be approved upon by both parties and a new revision of specifications shall be released to reflect the changes.

TST TAI-SAW TECHNOLOGY CO., LTD.

No. 3, Industrial 2nd Rd., Ping-Chen Industrial District,
Taoyuan, 324, Taiwan, R.O.C.

TEL: 886-3-4690038 FAX: 886-3-4697532

E-mail: tstsales@mail.taisaw.com Web: www.taisaw.com

SAW Resonator 850 MHz

MODEL NO.: TC0634A

REV. NO.: 2.0

A. FEATURES:

1. One-Port Resonator.

RoHS Compliant
Lead free
Lead-free soldering

B. MAXIMUM RATING:

1. Input Power Level: 0 dBm
2. DC voltage: 3 V
3. Operating Temperature: -40°C to +85°C
4. Storage Temperature: -40°C to +85°C
5. Moisture Sensitive Level: Level 1 (MSL1)

Electrostatic Sensitive Device (ESD)

C. ELECTRICAL CHARACTERISTICS:

Characteristic	Units	Minimum	Typical	Maximum
Center frequency Fr	MHz	849.80	850	850.20
Insertion Loss IL	dB	-	1.45	2.0
Equivalent Elements				
Motional capacitance C1	fF	-	1.39	-
Motional inductance L1	μH	-	25.1	-
Motional resistance R1	Ohm	-	13.6	-
Parallel capacitance Co	pF	-	2.62	-
Temp.coeff.	ppm/c*2	-	0.032	-
Turnover To	deg.C	-	25	-
Package size		SMD 3.0X3.0X1.4mm		

Temperature dependence of fc: $f_c(T_A) = f_c(T_O)(1 + TC_f(T_A - T_O)^2)$

D. EQUIVALENT CIRCUIT:

One-Port Resonator:

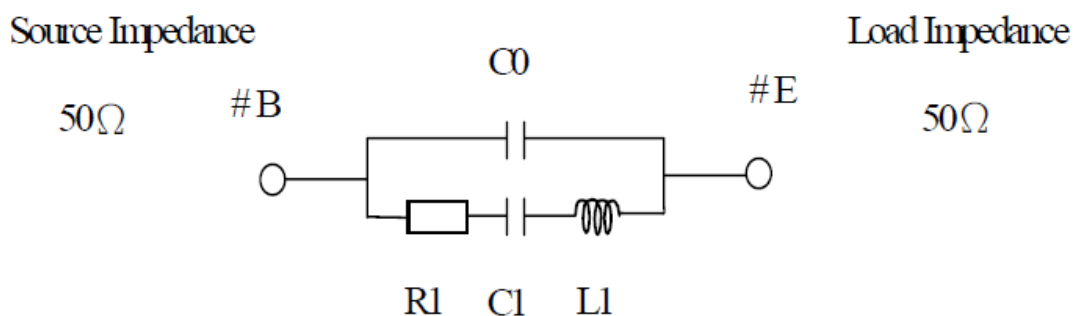

E. OUTLINE DRAWING:

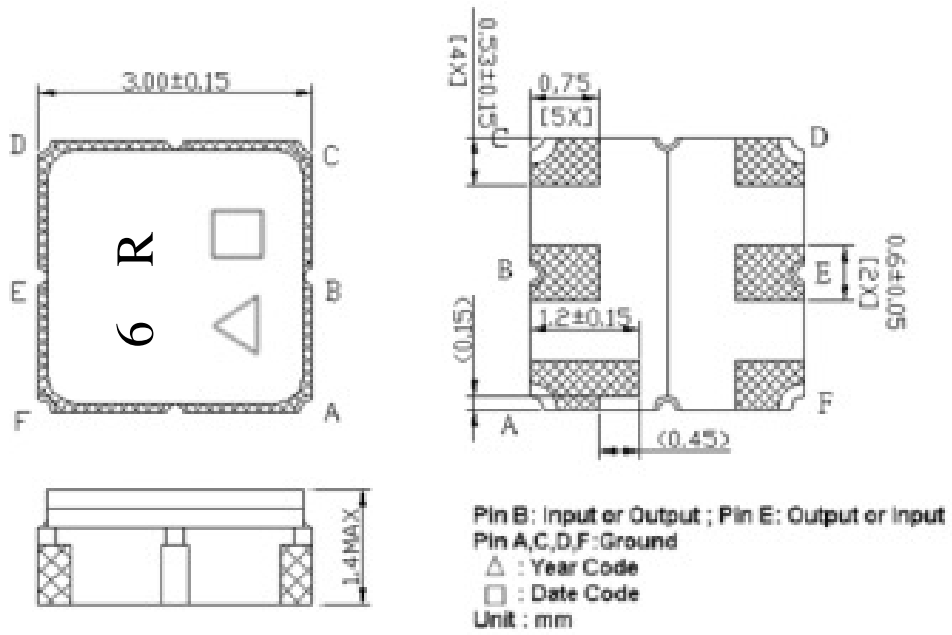

□ Date code :

WK01	WK02	WK03	WK04	WK05	WK06	WK07	WK08	WK09	WK10	WK11	WK12	WK13
A	B	C	D	E	F	G	H	I	J	K	L	M
WK14	WK15	WK16	WK17	WK18	WK19	WK20	WK21	WK22	WK23	WK24	WK25	WK26
N	O	P	Q	R	S	T	U	V	W	X	Y	Z
WK27	WK28	WK29	WK30	WK31	WK32	WK33	WK34	WK35	WK36	WK37	WK38	WK39
a	b	c	d	e	f	g	h	i	j	k	l	m
WK40	WK41	WK42	WK43	WK44	WK45	WK46	WK47	WK48	WK49	WK50	WK51	WK52
n	o	p	q	r	s	t	u	v	w	x	y	z

△ Year code :

Year	2014	2015	2016	...	2019	2020
Code	4	5	6	...	9	0

F. FREQUENCY CHARACTERISTICS:

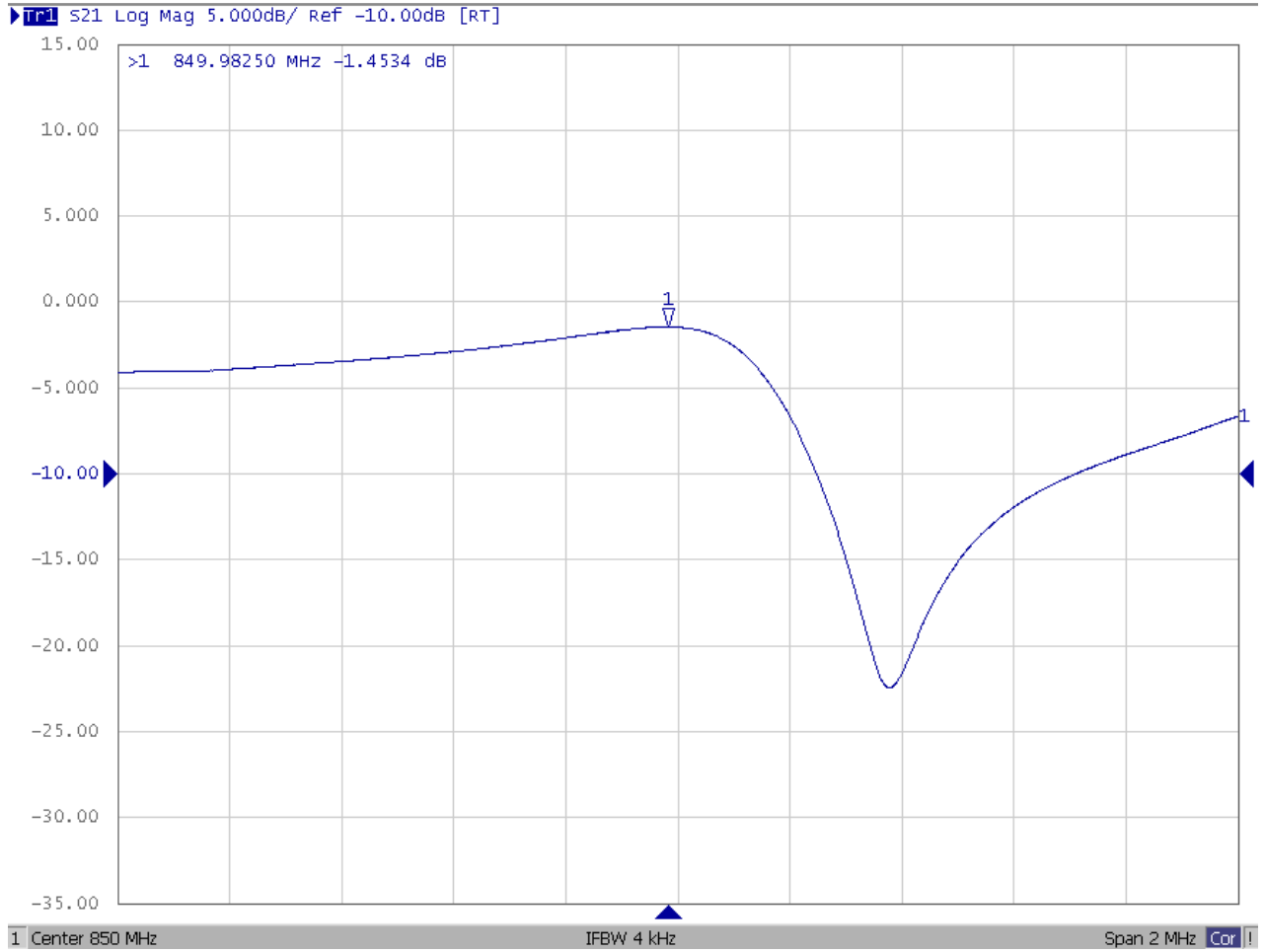

G. TEST CIRCUIT:

Network analyzer

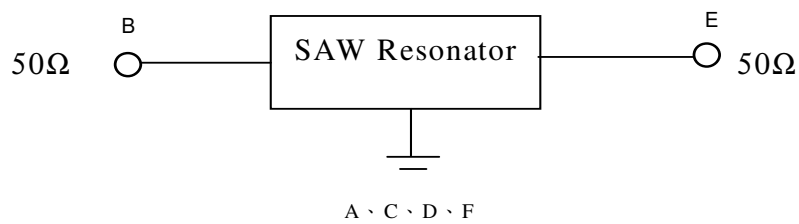

H.PCB FOOTPRINT

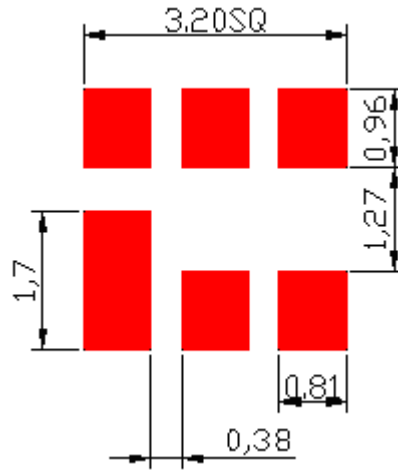

I. PACKING:

1. REEL DIMENSION

(Please refer to FR-75D10 for packing quantity)

